

REV	TARİH	AÇIKLAMA	CİZEN	ONAY
A	29.05.20	AIR OUT MOVED BACK SIDE	VS	RO

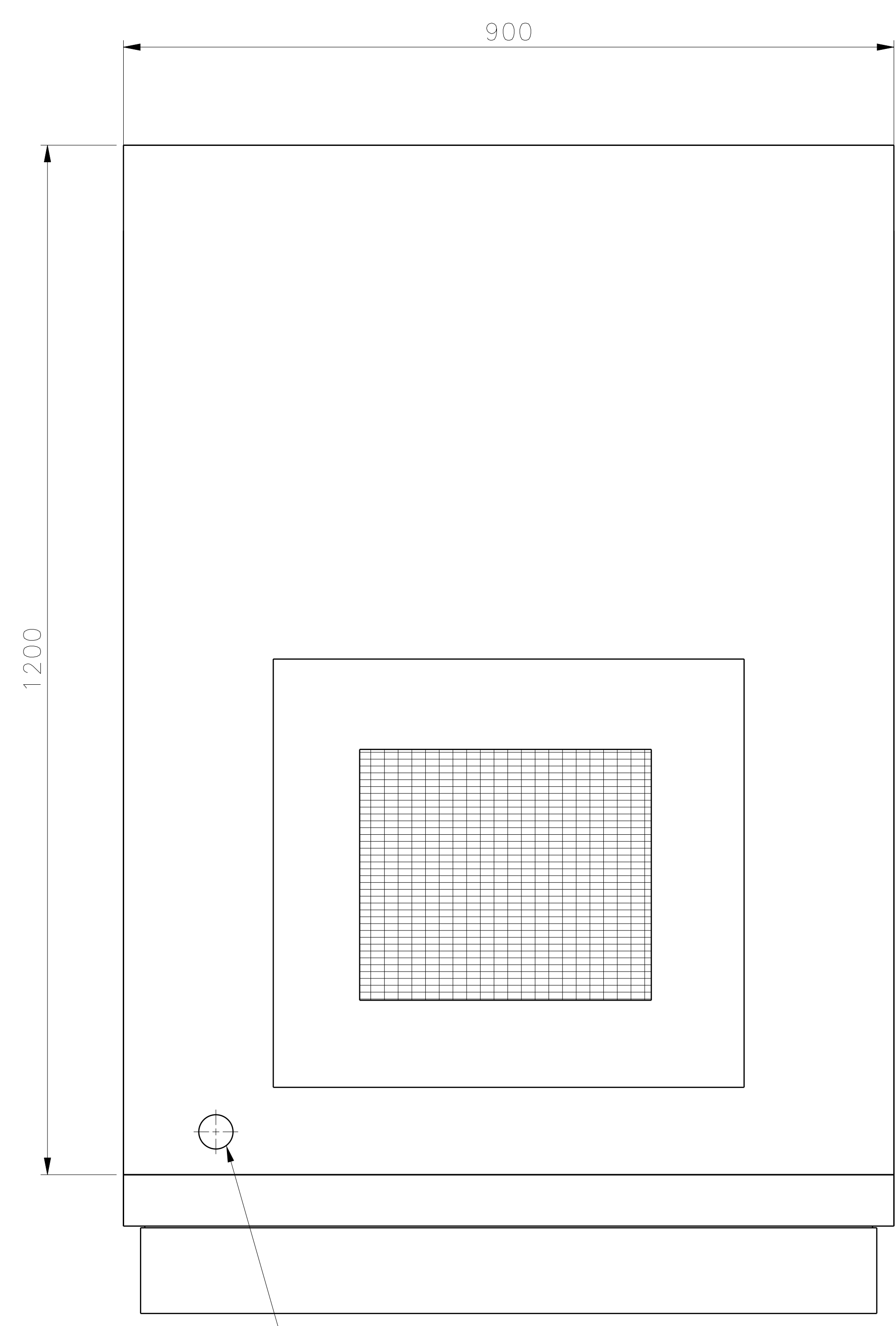

ELECTRICAL INLET

Right view
Scale: 1:4

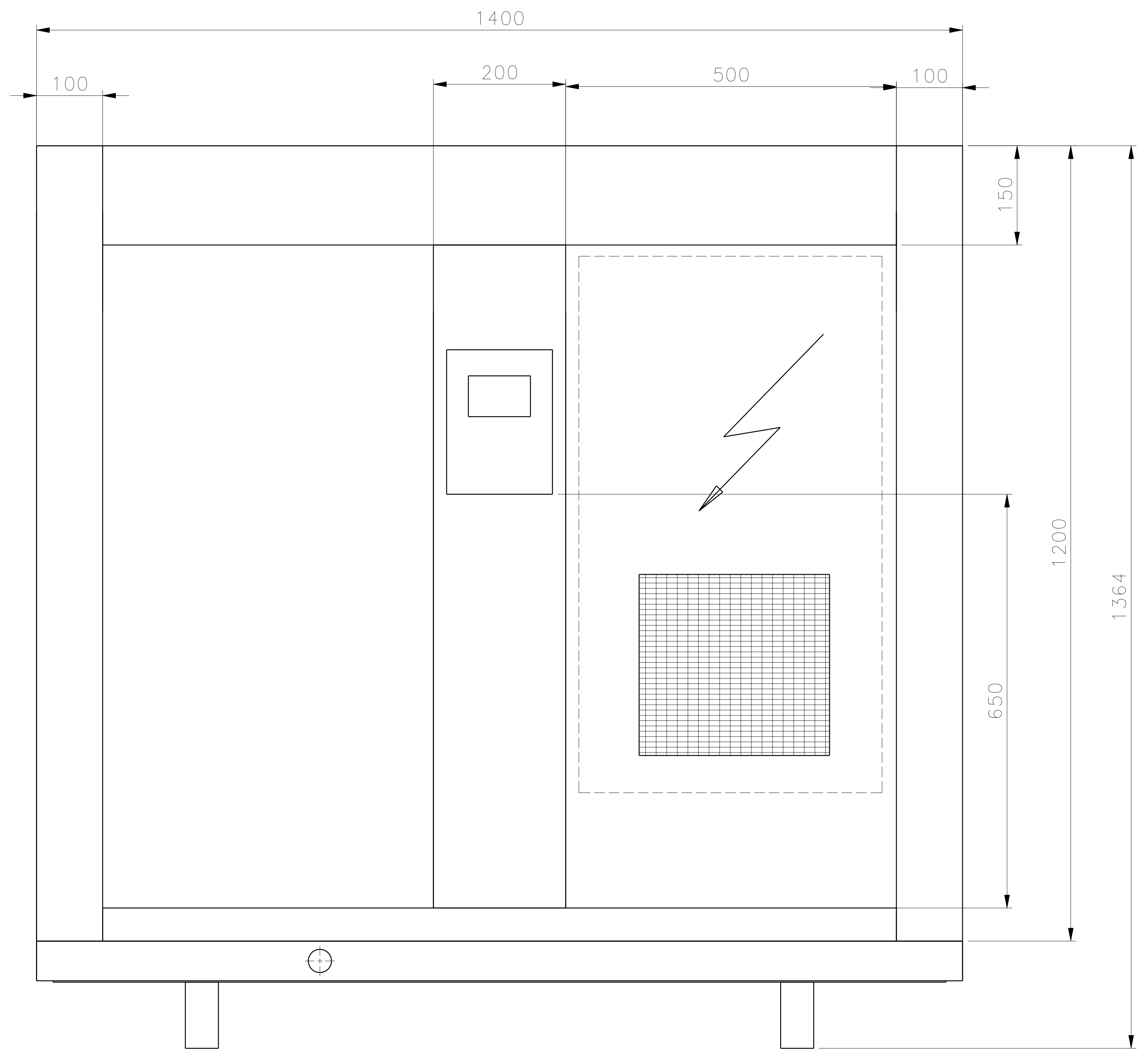

Front view
Scale: 1:4

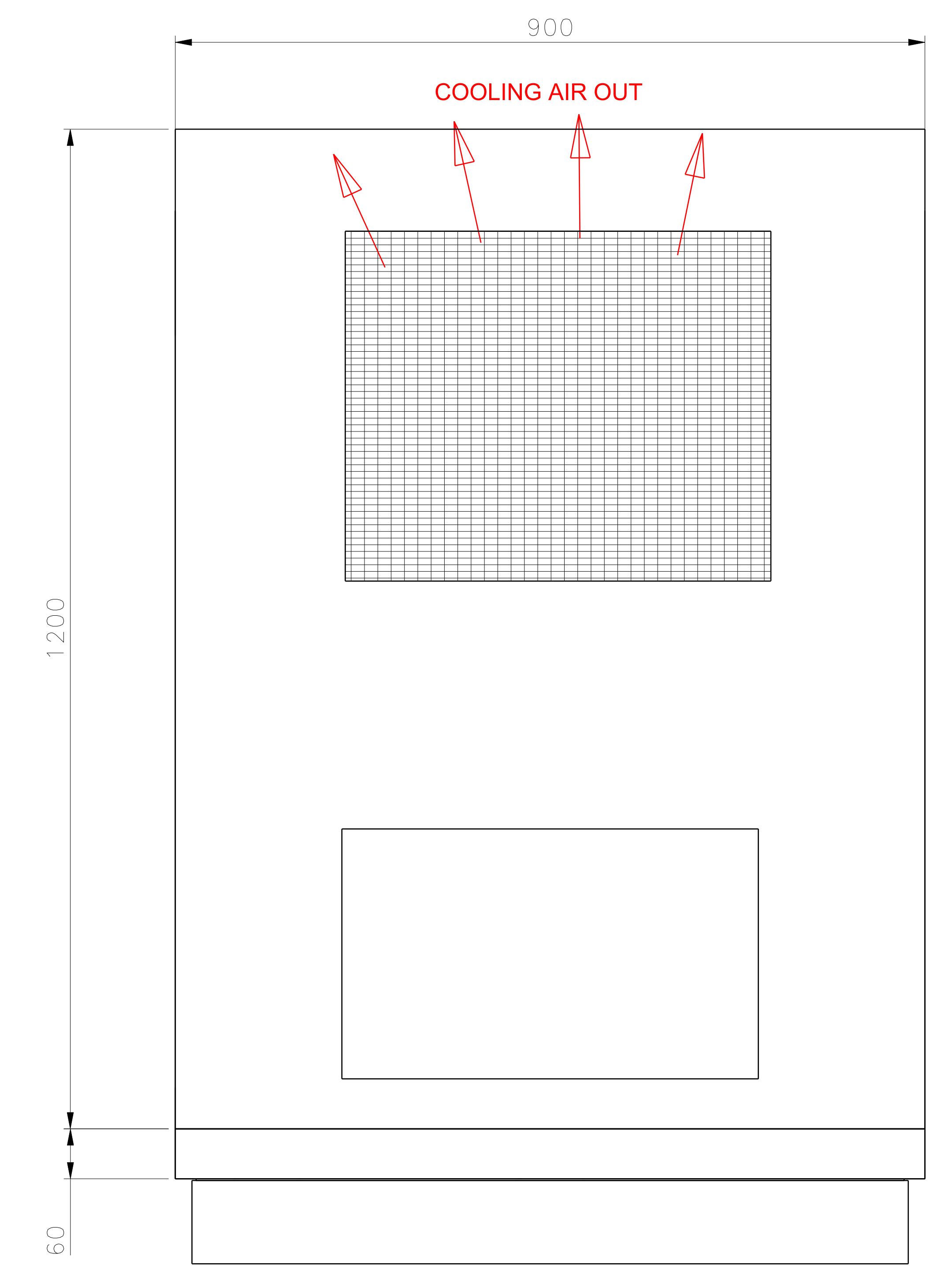

Left view
Scale: 1:4

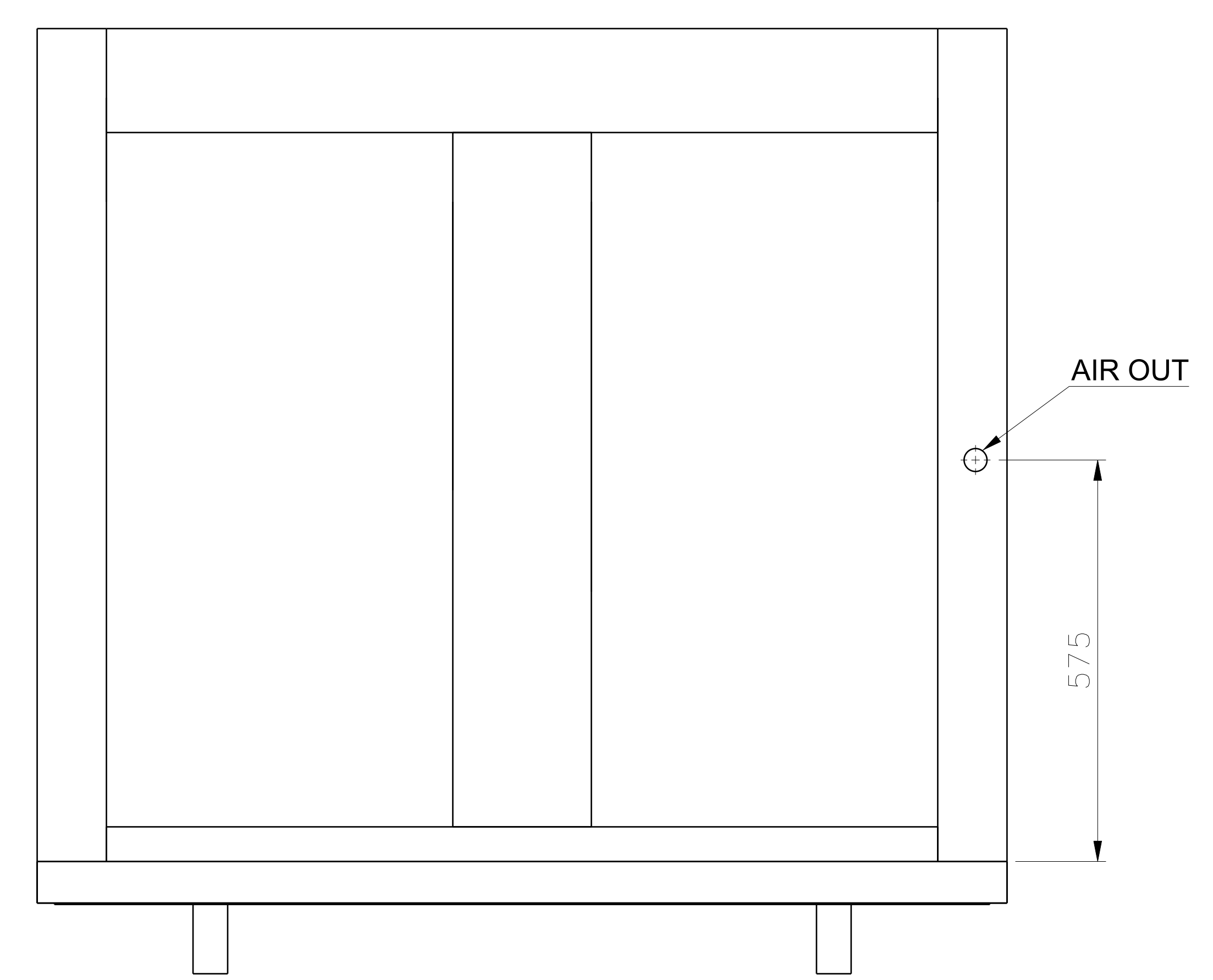

Rear view[2]
Scale: 1:6

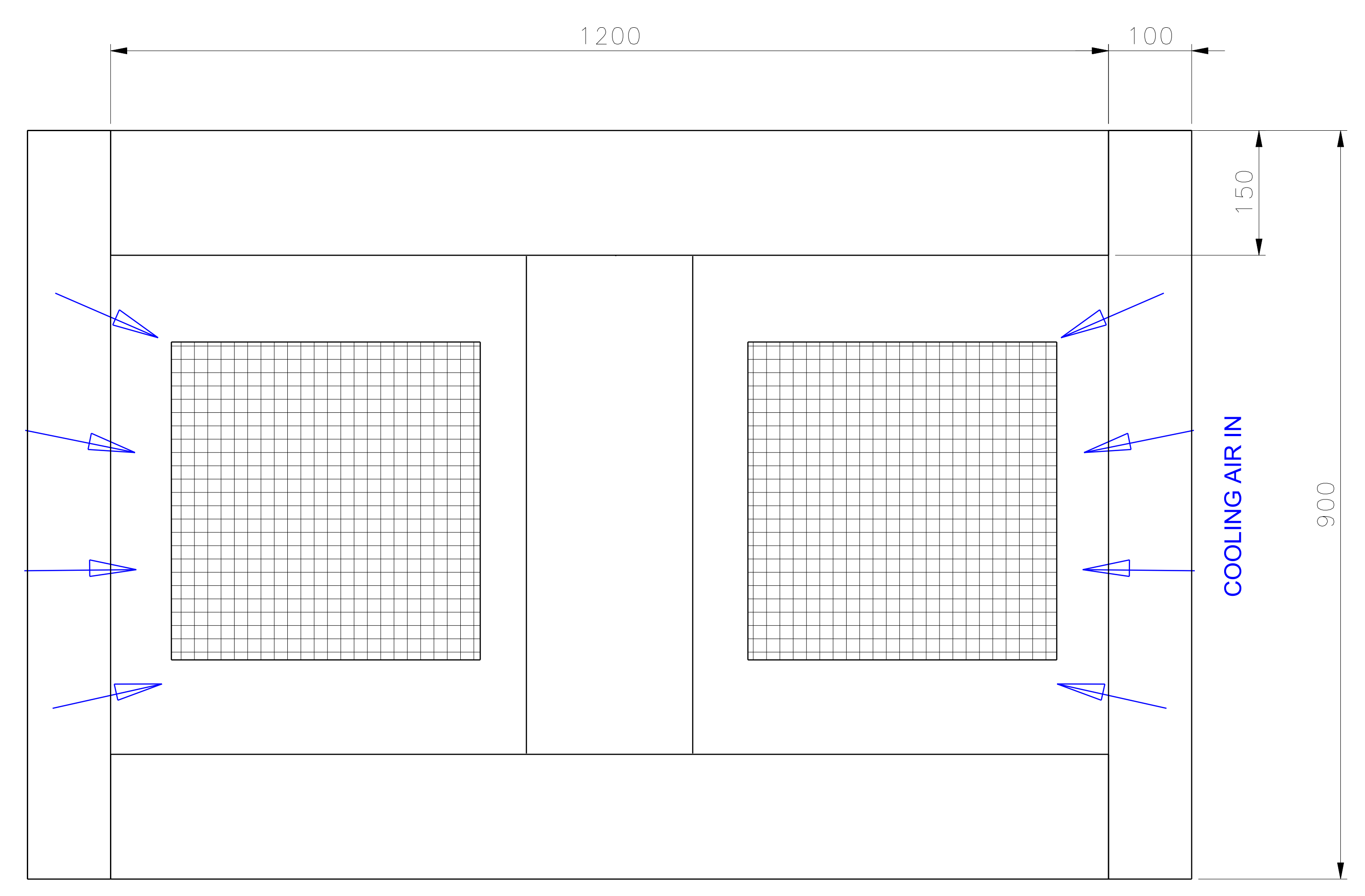

Top view
Scale: 1:4

25.05.2021

ITEM NO.	QTY	CODE	IDENT	PART OR IDENTIFYING NO.	NOMENCLATURE OR DESCRIPTION	MATERIAL	SPECIFICATION	ZONE
LIST OF MATERIALS OR PARTS LIST								

THIS DRAWING IS THE PROPERTY OF ANKARA HAMAK İND. AND IS TRANSMITTED IN CONFIDENCE. NEITHER RECEIPT NOR POSSESSION CONFERS OR TRANSFERS ANY RIGHTS TO REPRODUCE, USE OR DISCLOSE, IN WHOLE OR PART, DATA CONTAINED HEREIN FOR ANY PURPOSE, WITHOUT THE WRITTEN PERMISSION OF ANKARA HAMAK İND.

UNLESS OTHERWISE SPECIFIED DIMENSIONS ARE IN INCHES TOLERANCES ON		CONTRACT NUMBER		ERS VSD 22 COMPRESSOR DIRECT DRIVE	
FRACTIONS	DECIMALS	DATE OF DRAWING			
± .X ± .5		14 JAN 2016		CODE IDENT NO.	
ANGELS	.XX ± .25	DRAFTSMAN	CHECKER		
± 1"	.XXX ±	M. SİMSEK	V. SAKAL	SIZE A0	
		ENGINEER	FUNCTIONAL DESIGN		
		I. ÜRKÜT		DRAWING NO. D0-0220-8155	
		MANUFACTURING	WELDING		
NEXT ASSY	USED ON	APPROVED		SCALE	UNIT WT
		R. ÖKÇÜN			500 KG
APPLICATION				SHEET	OF

