

REV	DATE	DESCRIPTION	DWG	APPR
A	02.05.17	SAME CABIN 11 - 15 ACCORDING A NEW UNIT	VS	RO
B	12.07.18	ADD OPENING TO THE COVER	VS	RO

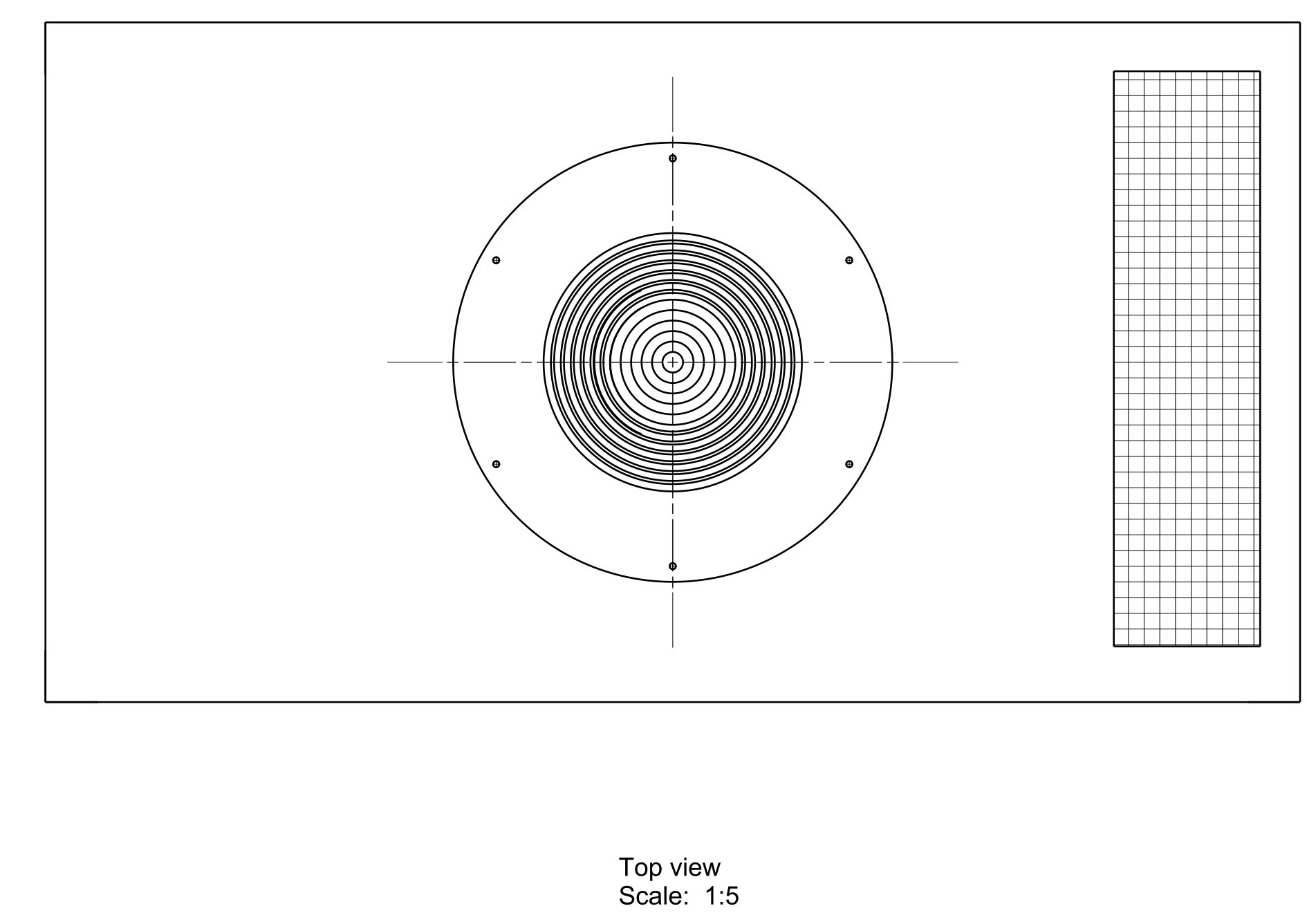

25.05.2021

ITEM NO.	QTY	CODE	IDENT	PART OR IDENTIFYING NO.	NOMENCLATURE OR DESCRIPTION	MATERIAL	SPECIFICATION	ZONE
LIST OF MATERIALS OR PARTS LIST								
THIS DRAWING IS THE PROPERTY OF ANKARA HAMAK IND. AND IS TRANSMITTED IN CONFIDENCE. NEITHER RECEIPT NOR POSSESSION CONFERS OR TRANSFERS ANY RIGHT TO REPRODUCE, USE OR DISCLOSE, IN WHOLE OR PART, DATA CONTAINED HEREIN FOR ANY PURPOSE, WITHOUT THE WRITTEN PERMISSION OF ANKARA HAMAK IND.								
UNLESS OTHERWISE SPECIFIED DIMENSIONS ARE IN INCHES TOLERANCES ON					CONTRACT NUMBER			
FRACTIONS DECIMALS					DATE OF DRAWING			
± .X ± .5					14 APR 2014			
ANGLES .XX ± .25					DRAFTSMAN			
± .XXX ±					V_SAKAL			
					CHECKER			
					I_KARAHAN			
					ENGINEER			
					I_URKUT			
					FUNCTIONAL DESIGN			
					MANUFACTURING			
					WELDING			
					CODE IDENT NO.			
					SIZE			
					A0			
					DRAWING NO.			
					WK-0110-9000			
NEXT ASSY USED ON APPLICATION					APPROVED			
					R.ÖKÇÜN			
					SCALE			
					UNIT WT			
					LB			
					SHEET			
					OF			

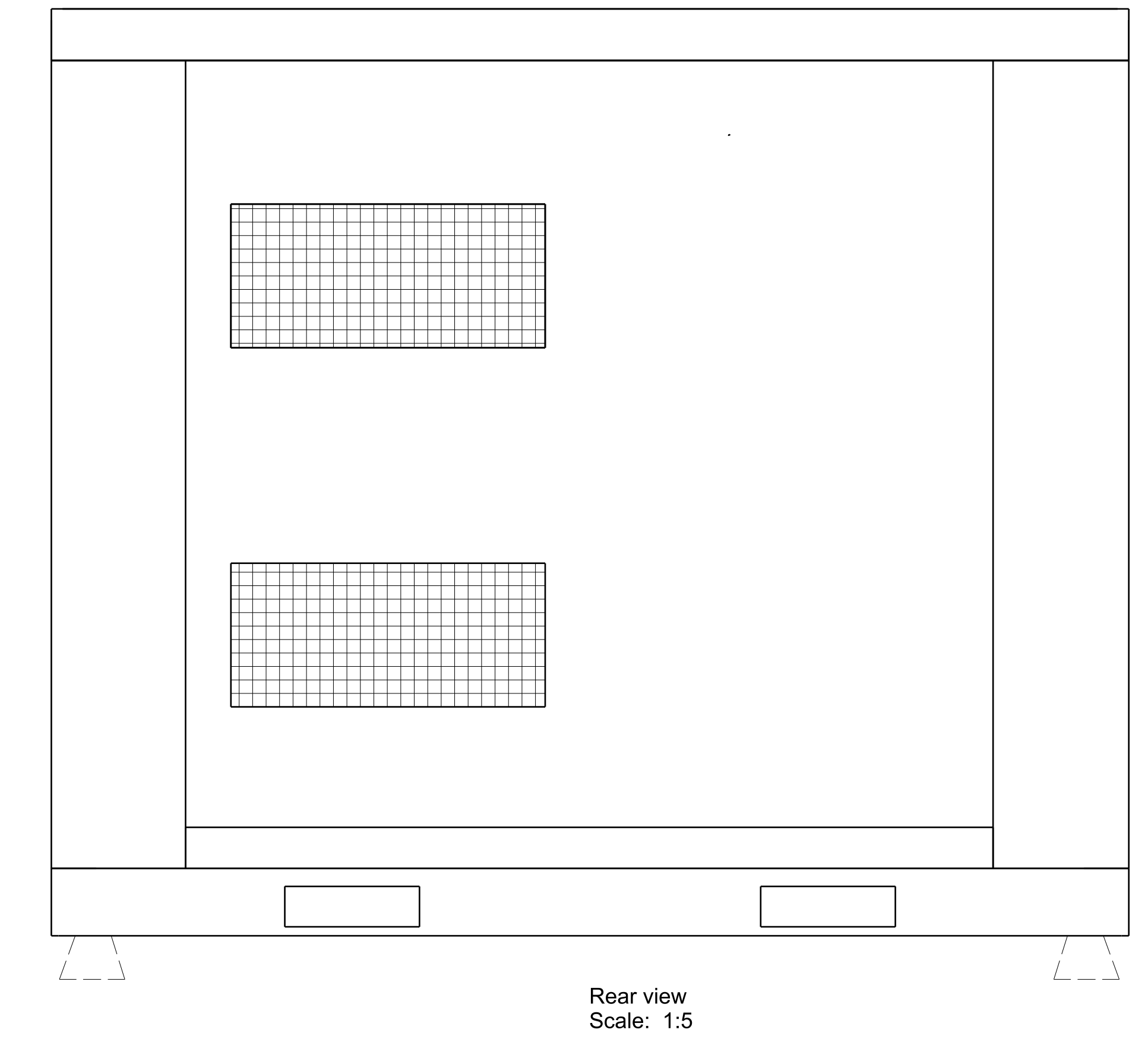
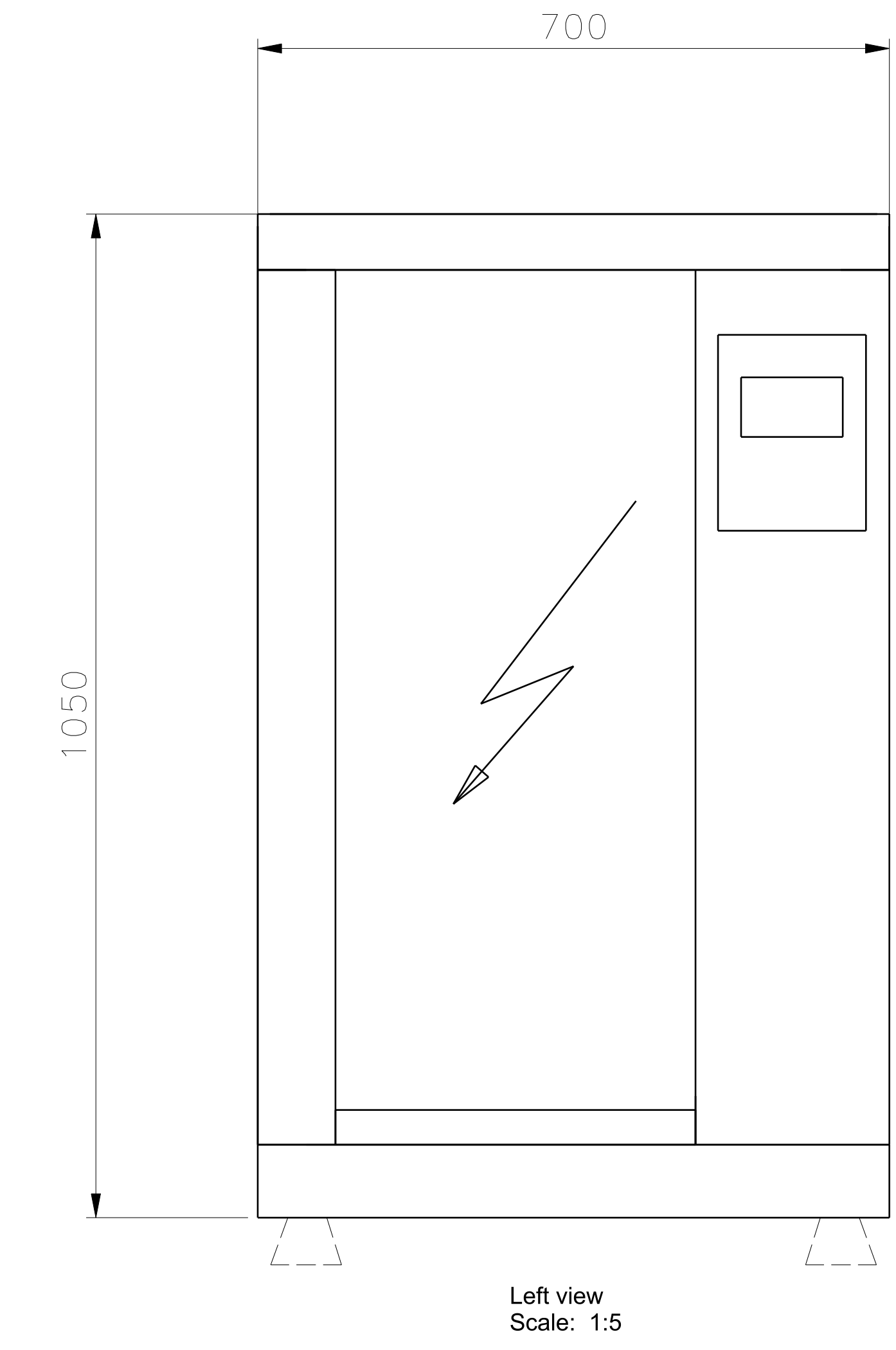
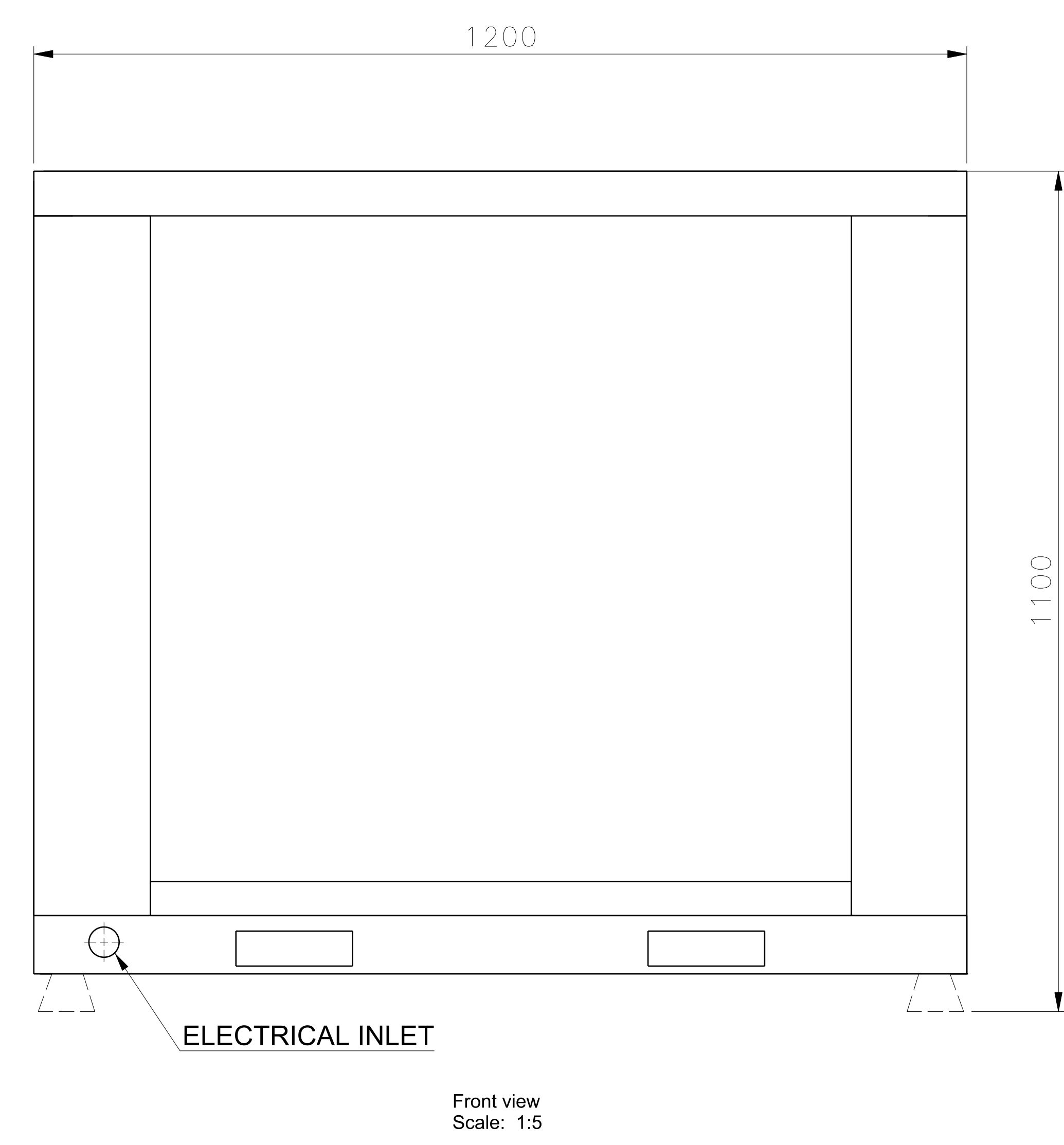
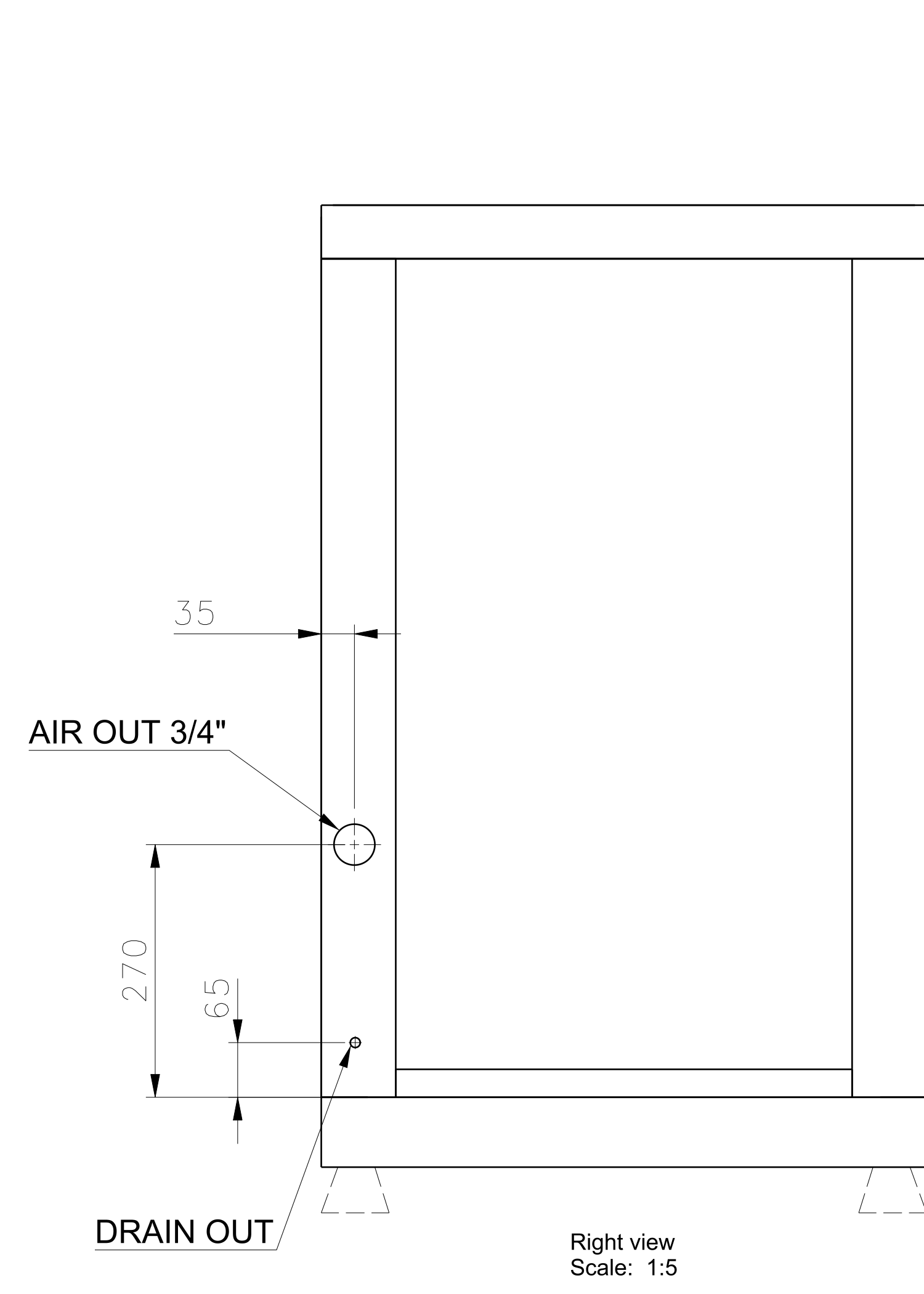

SCROLL COMPRESSOR
VOFS 5,5 X 2 - 11 KW